

356i ATC Cabinet



Cabinets

Controllers

Signals

Signs

Software

Specialty

Overview

The 356i ATC Cabinet is part of McCain's revolutionary ATC cabinet series which combines the best of rack mount and serial-based designs to meet the needs of today's LED intersections. Using smarter, high-density components, ATC cabinets offer unparalleled control capabilities for intersections that would otherwise require unorthodox wiring or even a second cabinet. Users rave about the drastically reduced assembly size that allows for maximum functionality while providing room for auxiliary equipment.

Benefits

- Safeguard against accidental shock from inadvertent contact with high voltages
- Comply with leading standards on electrical safety, including NEC and NFPA 70E
- Detect a dark approach for increased driver safety
- Monitor FTR and flasher continuously to ensure operability
- Allow for hot swappable output assembly for improved intersection safety

Product Description

The McCain 356i ATC Cabinet's modern design and advanced safety features complement the operational capabilities of ATC controllers and aim to protect agency, personnel, and public interests. These unrivaled benefits include load current monitoring to detect a dark approach, no AC power exposed to reduce accidental contact with high voltages, and the ability to keep the intersection in flash while replacing the output assembly.

Each 356i ATC Cabinet comes configured to meet individual needs using one or more input and output assemblies to provide the necessary phasing, overlaps, and channels. The cabinet can manage up to 24 detector inputs and 16-channel outputs without any complex wiring.

The 356i ATC Cabinet offers robust functionality in a form factor that can be base, pedestal, or pole mounted.

356i ATC Cabinet

Rear

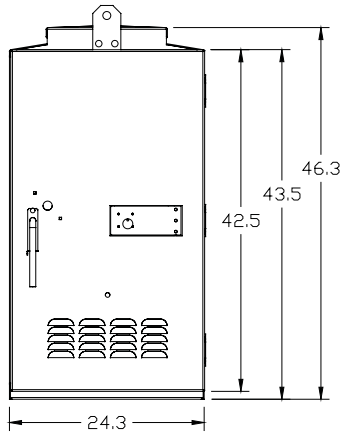

Side

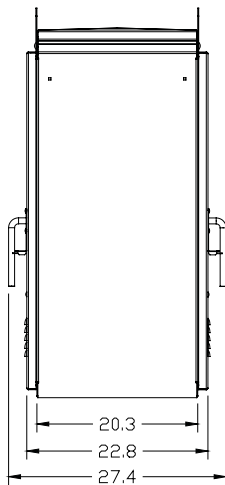

Base

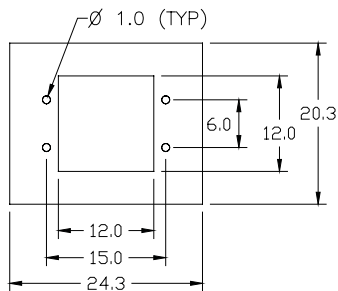

Dimensions rounded to the nearest 0.1"

Standard Features

- Field output termination assembly provides removable contact blocks for easy connections to field signal wires, sockets for flash transfer relays (FTRs), and flash program blocks (FPBs) for output channels
- All channels are flashable and programmable
- FPBs control and select the color (red, yellow, or dark) during flash
- Hermetically sealed high-density FTR features an LED indicator to visually confirm relay is operational and contacts have transferred
- Interior LED cabinet lights (2), front and back
- Model 2202 dual flasher/switch pack combination
- Exterior is continuously welded

Assemblies & Components

- 24 or 48-channel input assembly
- 2 or 4-channel industry standard detection modules
- Uses industry standard input components (i.e. loop amplifiers, PPB, EVP, etc.)
- 16-channel output assembly
- 32-channel CMU
- CMU auxiliary display unit
- Model 2216-24 cabinet power supply
- DC power / communication assembly
- Clean AC power assembly
- Police panel with On/Off, MCE, Auto/Flash, and Interval Advance push button cable
- Slide-out drawer for storing programming blocks, plans, etc.
- Fan panel assembly

General Specifications

| | |
|------------------|--|
| Dimensions: | 46" H x 24"W x 20" D (rounded to the nearest inch) |
| Material: | 5052-H32 aluminum, 0.125" thick |
| Finishes: | Natural, anodized, or powder coated |
| Access: | Front door (1), back door (1), both full size |
| Latching System: | 3-point, choice of Corbin or Best locks |
| Handles: | 3/4" round, stainless steel with padlock hasp |
| Door Stops: | 90° (±10°), each door, top 90° and 180° (±10°), each door, bottom |
| Rack Assembly: | Removable 19" EIA rack |
| Ventilation: | Thermostatically controlled 100 CFM fan Louvered air intake in door, pleated filter |
| Mounting: | Base, pole, or pedestal mounted |
| Shipping Weight: | 200 lbs without plug-ins or controller |

Options

- ATC Cabinet Test Display
- 3/4" x 16" anchor bolts for mounting (4)

To learn more about
McCain's Integrated Traffic
Solutions, please contact
info@mccain-inc.com or
call (760) 727-8100



2365 OAK RIDGE WAY // VISTA, CALIFORNIA 92081 // USA // WWW.MCCAIN-INC.COM

© 2017 McCain Inc. Updated 10/20/17. McCain reserves the right to change product specifications without notice.
For the most up-to-date information, please contact McCain.