

# 336 Controller Cabinet

336A Standard  
336S Stretch



Stretch



Standard

## Cabinets

Controllers

Signals

Signs

Software

Specialty

## Overview

McCain's 336 Controller Cabinet is a versatile, compact, and rugged cabinet that can be either base, pedestal or pole mounted. This cabinet meets all Caltrans and Federal Highway Administration (FHWA) requirements. Convenient access to all interior assemblies and field terminations is available through two access doors, one front and one back. The cabinet is compatible with 170 or 2070 controllers and comes equipped with a 19-inch Electronics Industry Alliance (EIA) rack. The 336 cabinet shares many of the features of larger cabinets but with the added benefit of its small and compact design. The cabinet is also available in a taller version (336S) that provides approximately six inches of additional rack space.

## Benefits

- Compact size and versatile standard features promote maximum flexibility for intersection planning
- Standard assemblies assure interchangeability between manufacturers
- Variety of mounting positions increases flexibility and options for intersection design
- Available anti-graffiti coating reduces the effects of vandalism
- Available in standard (336A) and stretch (336S) models to meet your housing needs

## Product Description

The McCain 336 Controller Cabinet provides a unique advantage over its larger counterparts through its compact and versatile design. This cabinet can house all of the equipment necessary to control an eight phase, four pedestrian operation with two overlaps while still offering flexible mounting options.

Its 12 loadswitch positions can all be programmed ("Yellow/Red", "All Red", or "No Flash") and a police panel comes standard with "On/Off" and "Auto/Flash" switches. This cabinet also features two railroad and four emergency vehicle preemption inputs, provides 16 detector channels (one per left turn, three per through movement), and is compatible with two-channel or four-channel detectors.

Flexible assembly set-up allows the 24 VDC power supply and Power Distribution Assembly (PDA) to be combined as one assembly or left as separate assemblies.

# 336 Controller Cabinet

Front

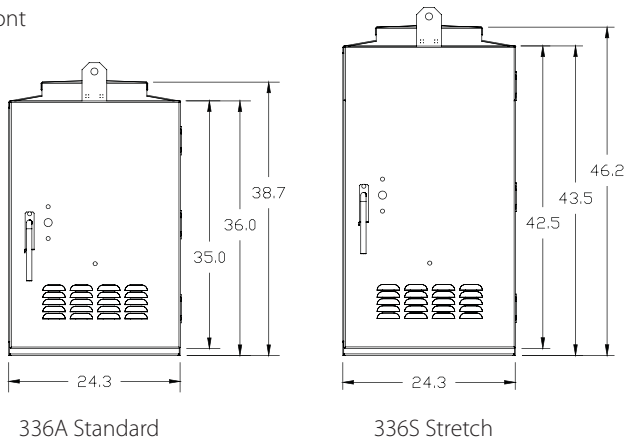

Side

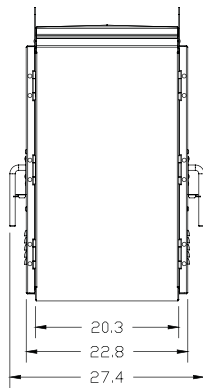

Back

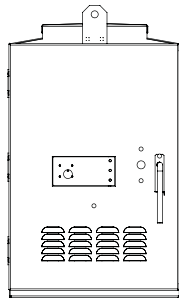

Base

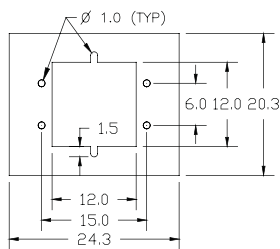

Base dimensions are the same on the standard and stretch models.

*Dimensions rounded to the nearest 0.1"*

## Standard Features

- 8-phase, 4-pedestrian operation (2 overlaps)
- 16 detector channels (1 per left turn, 3 per through movement)
- 2-channel or 4-channel industry standard detection modules
- Railroad preemption inputs, AC isolation (2)
- Emergency vehicle preemption inputs (4)
- Programmable "Yellow/Red", "All Red" or "No Flash" available for all loadswitch positions
- DC isolation inputs for pedestrian push buttons and special functions
- 210 Signal Monitor slot

## Assemblies

- 14-position input file
- 12-position output file
- 24 VDC power supply
- Power Distribution Assembly (PDA-2) with combined power supply
- Flash transfer relay sockets (4)
- Dual-circuit flasher positions (2)
- Service panel
- Police panel with signal "On/Off" and "Auto/Flash" switches
- Controller shelf

## General Specifications

- Dimensions: 39" H x 24" W x 20" D (rounded to the nearest inch)
- Material: 5052-H32 aluminum, 0.125" thick
- Finishes: Natural, powder coat (standard, anti-graffiti, and custom colors), anodized
- Access: Front door (1), back door (1), both full size
- Latching System: 3-point, choice of Corbin or Best locks
- Handles: 3/4" round, stainless steel, with padlock feature
- Door Stops: 90° and 180° (±10°), each door, bottom
- Rack Assembly: Removable 19" EIA rack
- Ventilation: Thermostatically controlled 100 CFM fan  
Louvered air intake in door, pleated filter
- Mounting: Base, pedestal, or side of pole mounting
- Shipping Weight: 265 lbs without plug-ins or controller(s)

## Options

- Mounting equipment: anchor bolts for base mounting (4), brackets for side pole mounting, and hardware for pedestal mounting
- Removable aluminum hex key door handle
- 336S stretch option available:
  - Dimensions: 46" H x 24" W x 20" D (rounded to the nearest inch)
  - Shipping Weight: 280 lbs without plug-ins or controller(s)
- Auxiliary output file (336S only)
- Various additional options available, please contact McCain

To learn more about McCain's Integrated Traffic Solutions, please contact [info@mccain-inc.com](mailto:info@mccain-inc.com) or call (760) 727-8100



2365 OAK RIDGE WAY // VISTA, CALIFORNIA 92081 // USA // [www.mccain-inc.com](http://www.mccain-inc.com)

© 2008 McCain Inc. Updated 10/03/08. McCain reserves the right to change product specifications without notice. For the most up-to-date information, please contact McCain.