

Enforcer

Red Light Violator Detection Unit



Cabinets
Controllers
Signals
Signs
Software
Specialty

Overview

McCain's Enforcer is a red light violator detection unit designed to help law enforcement agencies reduce the number of red light violations. According to the Department of Transportation, running red lights is the leading cause of urban collisions. Each year in the United States, red light violations result in roughly 1,000 deaths and over 150,000 injuries. The McCain Enforcer is a low-cost, easy-to-install, effective alternative to a red light camera that works toward the same goal - reduction of red light violations and safer streets for the public.

Benefits

- Easy to install and connect to existing signals
- Fully adjustable viewing angle
- Visible from hundreds of feet away
- LED's available in four colors
- Low power consumption operates on the same voltage as signals

Product Description

The McCain Enforcer is a small, highly directional LED light, that allows law enforcement to observe the status of a red light from a cross street. When the Enforcer is illuminated it indicates a red light so law enforcement can easily monitor motorists running the light.

The Enforcer's high-intensity LED's are mounted on a circuit board that is encased in a weather resistant, tubular housing allowing it to operate in any environment. An integrated sun visor promotes visibility in direct sunlight. The housing is attached to a standard one-and-a-half-inch NPT ornamental cap that can be mounted in a variety of positions. Two 15-foot-long, color-coded (red and white) leads connect to the existing red light voltage terminals, allowing the Enforcer to indicate the exact state of the red light. An in-line fuse holder is also provided.

The Enforcer is available in four LED colors: red, blue, white, and amber.

Enforcer

3-D

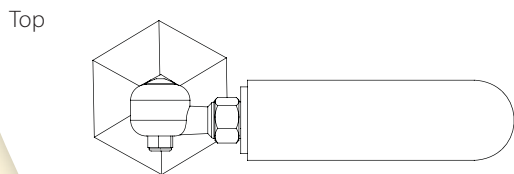
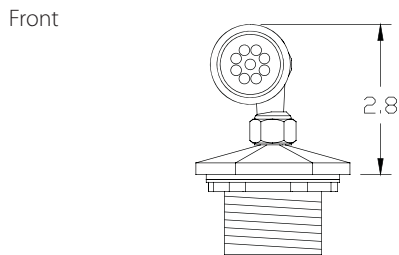
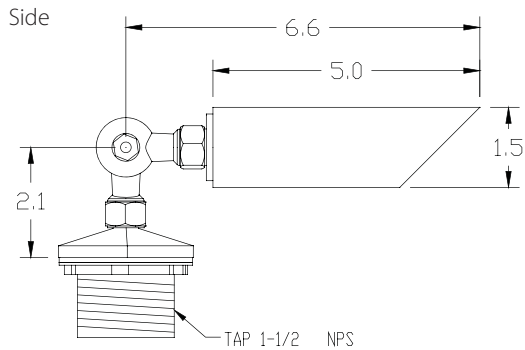
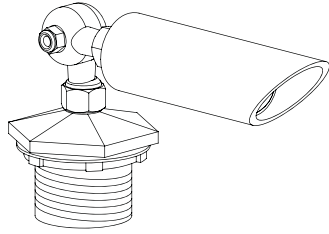

Dimensions rounded to the nearest 0.1"

Standard Features

- LEDs are mounted on a circuit board
- Constant current driving electronics
- Electronics sealed in weather-resistant enclosure
- 360° horizontal and 215° vertical adjustment
- Ornamental mounting cap includes gasket, washer, and locking nut
- In-line fuse holder
- 15' wire leads

General Specifications

Dimensions:	Housing: 5.0" long x 1.5" diameter Length including distance to center of elbow: 6.6" Height including distance to cap bottom: 2.8"																				
Material:	6061-T1 aluminum, 0.125" wall thickness																				
Finishes:	Powder coated black																				
LED's:	<table><thead><tr><th></th><th><u>Red</u></th><th><u>Amber</u></th><th><u>White</u></th><th><u>Blue</u></th></tr></thead><tbody><tr><td>Technology</td><td>AllInGaP</td><td>AllInGaP</td><td>InGaN</td><td>InGaN</td></tr><tr><td>Viewing Angle¹</td><td>23°</td><td>30°</td><td>23°</td><td>15°</td></tr><tr><td>Wavelength²</td><td>630 nm</td><td>591 nm</td><td>x=0.31, y=0.31³</td><td>470 nm</td></tr></tbody></table>		<u>Red</u>	<u>Amber</u>	<u>White</u>	<u>Blue</u>	Technology	AllInGaP	AllInGaP	InGaN	InGaN	Viewing Angle ¹	23°	30°	23°	15°	Wavelength ²	630 nm	591 nm	x=0.31, y=0.31 ³	470 nm
	<u>Red</u>	<u>Amber</u>	<u>White</u>	<u>Blue</u>																	
Technology	AllInGaP	AllInGaP	InGaN	InGaN																	
Viewing Angle ¹	23°	30°	23°	15°																	
Wavelength ²	630 nm	591 nm	x=0.31, y=0.31 ³	470 nm																	
	¹ 20½	² Peak λ	³ CIE 1931																		
	All values @ 20 mA forward current																				

Input Voltage: 20 VAC to 150 VAC
40 Hz to 100 Hz

Power: 7.2 VA (at 110 VAC)

Mounting: Standard 1.5" NPS ornamental cap/elbow

Sun Visor: Integral part of housing

Environmental: Operating temperature: -40°C to +85°C
Humidity: 0 to 95% (non-condensing)

Shipping Weight: 1 lb 5 oz

Mounting

Mounting cap fits top port of signal housing (see photo on front) or any other 1-1/2" NP straight-thread fitting.

Alternately, the elbow/tube combination may be removed from the cap and reinstalled in a 5/8" hole drilled in any convenient location, such as the side of a terminal housing, that has a red-light wire connection point within the lead length of the Enforcer (15').

Part Numbers

Red:	M65177
Blue:	M65229
White:	M65448
Amber:	M69378

Options

- Custom housing finishes and colors
- Custom cable lengths

To learn more about McCain's Integrated Traffic Solutions, please contact info@mccain-inc.com or call (760) 727-8100



2365 OAK RIDGE WAY // VISTA, CALIFORNIA 92081 // USA // WWW.MCCAIN-INC.COM

© 2010 McCain Inc. Updated 08/27/10. McCain reserves the right to change product specifications without notice. For the most up-to-date information, please contact McCain.