

Signal Framework

Side Pole
Post Top
Overhead
Mast Arm
Pedestrian
Pipe Fittings
Pole Hardware
Special / Custom



Cabinets
Controllers
Signals
Signs
Software
Specialty

Overview

McCain's Signal Framework collection covers the gamut of your signal needs including, side-of-pole and post top mountings, overhead mounting, mast arm mounts, post top and side-of-pole pedestrian framework, pipe fittings, hardware, and special/custom mounting options. All of McCain's framework options are built to McCain's high-quality standards and manufactured from high-grade materials providing you with a dependable and rugged product.

Benefits

- Compatible with standard signals, programmable signals, and pedestrian housings
- Standard 1½-11½ NPT, schedule 40
- Complete line of fittings, pole mounts, pipe and nipples, terminal compartments, and more
- Wide variety of mounting types and configurations

Product Description

The McCain Signal Framework collection is a long-lasting compliment to our complete line of signal heads and pedestrian signals.

8" and 12" signal heads can be combined in the same mountings, and are available in many standard configurations. Commonly featuring one to four signal heads per mount, framework is available for top-of-pole, side-of-pole, span wire, or mast arm, and with or without terminal compartments.

Based on a 1½-11½ NPT, schedule 40, McCain framework is industry-standard compatible. Pre-assembled frames come fully wired with 14 AWG wire for your convenience.

All framework is powder coated in standard or custom colors.

Framework Nomenclature and Description

Reference point for all framework designations is the door of the terminal compartment

Examples:

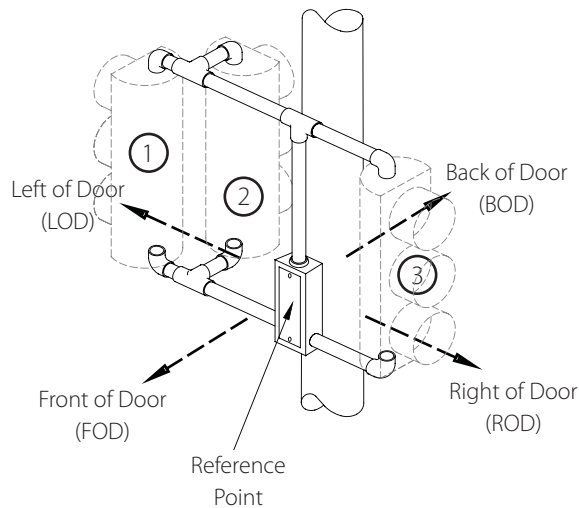

Example designation for unsymmetrical framework shown above:

Head No. 1	Offset LOD, outboard
Head No. 2	Offset LOD, inboard BOD
Head No. 3	Offset ROD

Standard Features

- 1½-11½ NPT
- 14 AWG THHN stranded wire

General Specifications

Dimensions:	Varies based on selected framework
Wall Thickness:	Schedule 40
Thread:	1½-11½ NPT (1½' diameter, 11½ threads per inch)
Material:	Steel, aluminium, or bronze, (specific materials may not be available for all framework items)
Finish:	Powder coated
Color(s):	Federal yellow, signal green, black, or custom colors
Mounting:	Side of pole, top of pole, mast arm
Environmental:	Operating temperature: -37°C to +74°C Humidity: 0 to 95% (non-condensing)
Shipping Weight:	Varies based on selected framework

Options

- Clamshell mount for pedestrian housings
- Other configurations and parts meeting specifications of many state Departments of Transportation are available. Please contact your McCain representative for further information

Details to Include When Ordering:

1. Material type for frame elements - steel, aluminium, or bronze (pole adaptor, slip fitting, terminal compartment, pole plate, etc.)
2. Signal face size (8", 12", or combo) and manufacturer of signal module (LED)
3. Designation (e.g., TV-2-T) indicating framework type
4. Orientation (left or right of door) of signal head mountings
5. Nipple lengths
6. Color

To learn more about
McCain's Integrated Traffic
Solutions, please contact
info@mccain-inc.com or
call (760) 727-8100



Top-of-Pole Mountings Without Terminal Compartments

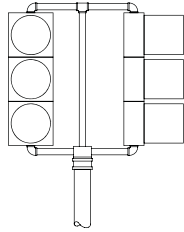
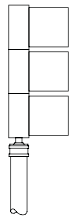
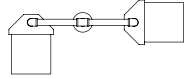

Caltrans: TV-1
ADOT: Type III

Caltrans: TV-2

Top-of-Pole Mountings With Terminal Compartments

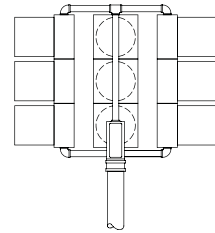
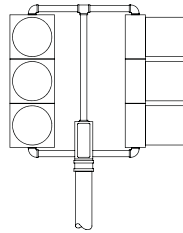
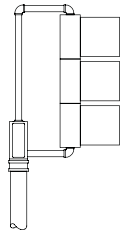
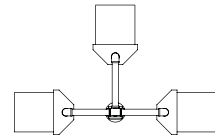
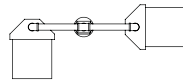
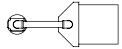

Caltrans: TV-1-T
ADOT: Type IV

Caltrans: TV-2-T
ADOT: Type VI

Caltrans: TV-3-T
ADOT: Type IX

Side-of-Pole Mountings Without Terminal Compartments

One Way

Two Way

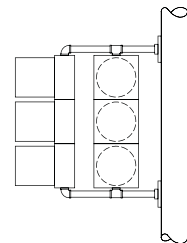
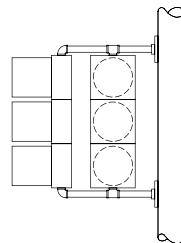
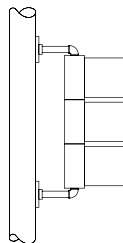
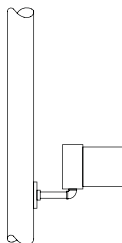
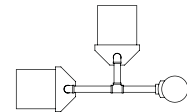
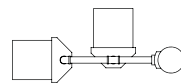
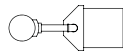
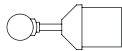

Caltrans: SV

Caltrans: SV-1
ADOT: Type XI

Caltrans: SV-2A

Caltrans: SV-2B

Note: All signals shown without backplates for clarity

Side-of-Pole Mountings With Terminal Compartments

One Way

Two Way

Three Way

Four Way

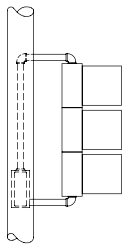

Caltrans: SV-1-T
ADOT: Type V
NDOT: B-1

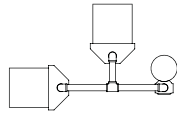

Caltrans: SV-2-TD
ADOT: Type VIII
NDOT: B-2b

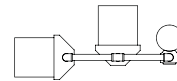

Caltrans: SV-2-TC
NDOT: B-2b

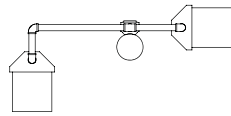

Caltrans: SV-2-TB

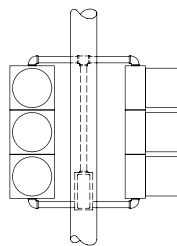
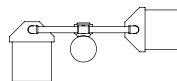

Caltrans: SV-2-TA
ADOT: Type VII

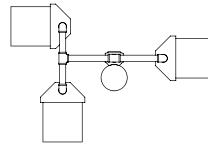

Caltrans: SV-3-TC
NDOT: B-3a

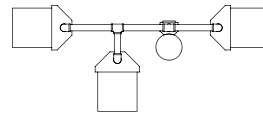

Caltrans: SV-3-TB
NDOT: B-3c

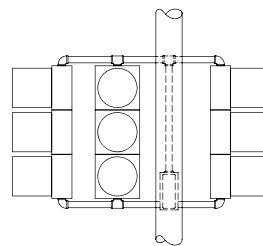
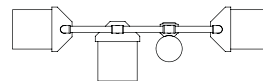

Caltrans: SV-3-TA
NDOT: N-3b

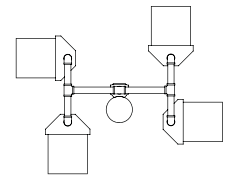

Caltrans: SV-4-TC

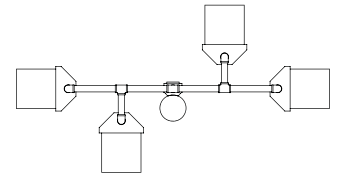

Caltrans: SV-4-TB

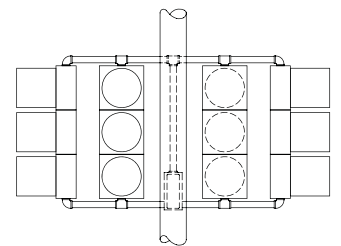
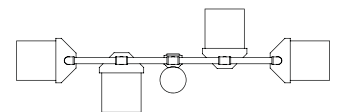

Caltrans: SV-4-TA

Note: All signals shown without backplates for clarity

To learn more about McCain's Integrated Traffic Solutions, please contact info@mccain-inc.com or call (760) 727-8100



Left Turn Mountings

No Terminal Compartment

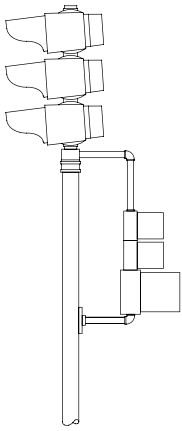

Caltrans: LT-2-A

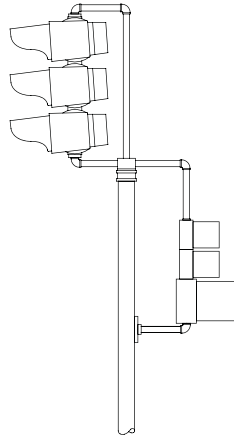

Caltrans: LT-2-B

With Terminal Compartment

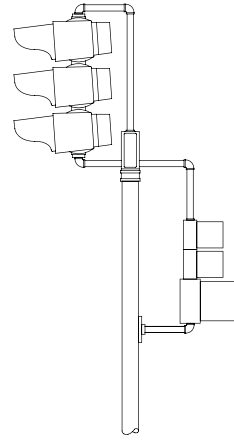

Caltrans: LT-2-T
ADOT: Type: X

Mast Arm Mountings

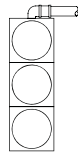

Caltrans: MAT
ADOT: Type I

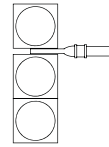

Caltrans: MAS
ADOT: Type II

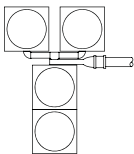

Caltrans: MAS-4A

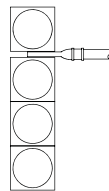

Caltrans: MAS-4B

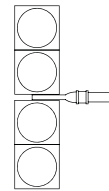

Caltrans: MAS-4C

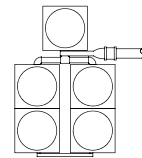

Caltrans: MAS-5A

Note: All signals shown without backplates for clarity

Span Wire Mountings

One Way



Caltrans: SW-1

Two Way



Caltrans: SW-2

Three Way



Caltrans: SW-3

Four Way



Caltrans: SW-4

Mast Arm Mountings

One Way



Caltrans: MAS



Caltrans: MAT-1

Two Way



Caltrans: MAT-2

Three Way



Caltrans: MAT-3

Four Way



Caltrans: MAT-4

Pedestrian Side-of-Post Mountings

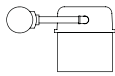

Caltrans: SP-1
ADOT: Type XI

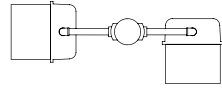

Caltrans: SP-2

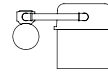

Caltrans: SP-1-T
ADOT: Type V
NDOT: WS-1 (modified)

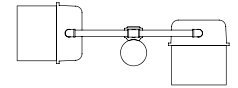

Caltrans: SP-2-T
ADOT: Type VII
NDOT: WS-2

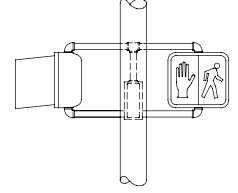
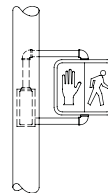
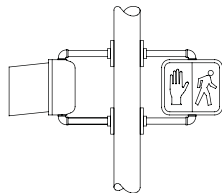
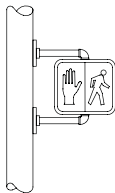

Note: ADOT Type VIII ped same configuration as Caltrans SV-2-TD signal

Pedestrian Top-of-Post Mountings



Caltrans: TP-1
NDOT: WT-1



Caltrans: TP-1-T
ADOT: TYPE IV

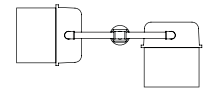

Caltrans: TP-2-T
ADOT: Type VI
NDOT: WT-2

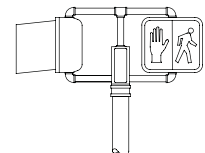
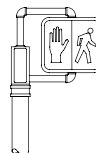
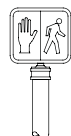

To learn more about McCain's Integrated Traffic Solutions, please contact info@mccain-inc.com or call (760) 727-8100



Adaptors and Mounts - Top-of-Pole

Cabinets
 Controllers
Signals
 Signs
 Software
 Specialty

		Aluminum	Bronze
	Adapter, terminal compartment, top-of-pole, 2-way (includes 12-position terminal block, door, & gasket)	M18810 (black)	M18812 (green) M68965 (black)
	Adapter, terminal compartment, top-of-pole, 3-way (includes 12-position terminal block, door, & gasket)	M18816 (green) M68964 (black)	M18817 (green) M68966 (black)
	Adapter, top-of-pole, offset mount, serrated (includes lock nipple)	M18510 (green) M31351 (black)	M18511 (green) M33300 (black)
	Adapter, top-of-pole, offset mount, serrated, 1 side port (includes lock nipple)	M34536 (green)	M18805-1 (green)
	Adapter, top-of-pole, center mount, plain, 2 side ports 180°	M18806	M18807
	Adapter, top-of-pole, center mount, plain, 4 side ports 90°	M45667 (green) M45669 (black)	M45668 (green) M45670 (black)
	Adapter, cabinet pedestal, top-of-pole, 4½" O.D. pole	M18872	M15323 (silver)

Notes:

1. All slip fittings furnished with set screws.
2. Bronze refers to compartment material. Doors are aluminum.
3. Customer must specify a color for part numbers not associated with a specific color as noted.
4. Colors other than those noted are available. Please contact your McCain representative.
5. na = not available.

Adaptors and Mounts - Side-of-Pole

		Aluminum	Bronze
	Adapter, terminal compartment, side-of-pole, 2-way, saddle back with cable guide (center of back) and mounting holes (includes 12-position terminal block, door, & gasket)	M18822	M18824 (green) M68967 (black)
	Adapter, terminal compartment, side-of-pole, 2-way, saddle back with cable guide (bottom of back) and mounting holes (includes 12-position terminal block, door, & gasket)	na	M18826 (green)
	Adapter, terminal compartment, side-of-pole, 2-way, flat back with cable entrance (center of back) and mounting holes (includes 12-position terminal block, door, & gasket)	M18877	M18879
	Terminal Compartment Door	M68962 (green) M68963 (black)	na
	Pole Plate without cable guide	na	M31251 (green)
	Pole Plate with cable guide	na	M30926 (green)
	Pole Plate, bandable	M18791	na

See notes previous page

To learn more about McCain's Integrated Traffic Solutions, please contact info@mccain-inc.com or call (760) 727-8100



Pipe Fittings, 1½-11½ NPT

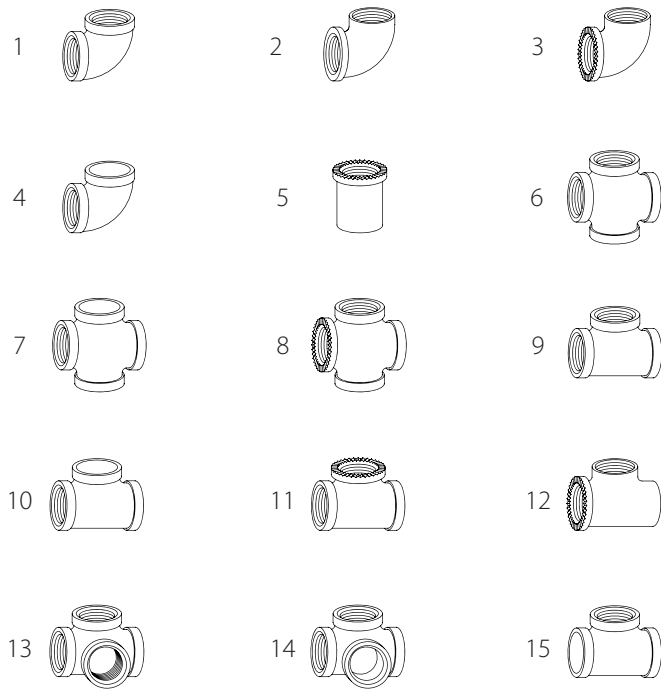

1. Elbow, standard
2. Elbow, flanged 1 port
3. Elbow, serrated one port
4. Elbow, slip fit one port
5. Coupling, serrated one port
6. Cross, standard
7. Cross, slip fit one port
Slip cross, slip fit two opposite ports
8. Cross, serrated 1 port
9. Tee, standard
10. Tee, slip fit side port
11. Tee, serrated side port
12. Tee, serrated run 1 port
13. Tee, side outlet
14. Tee, slip fit side outlet
15. Slip tee, slip fit on run 2 ports
Tee, slip fit on run 1 port

Note: All slip fittings furnished with set screws

Framework Parts, 1½-11½ NPT

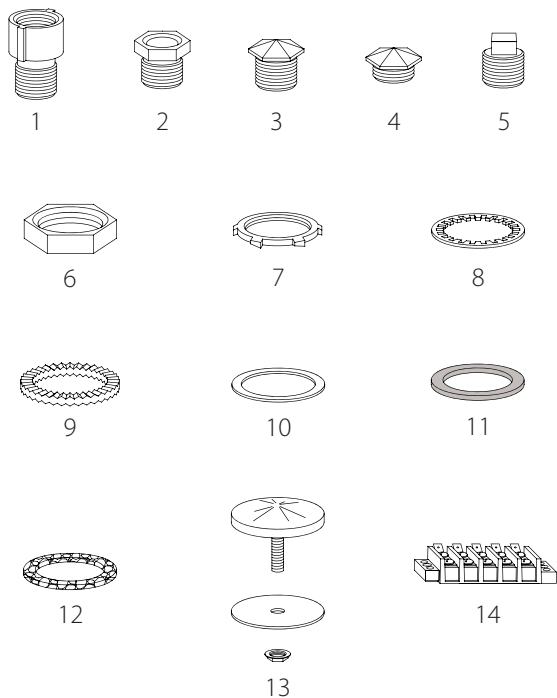

1. Extender, flanged
Extender, Shurlock
2. Lock nipple
3. Cap, ornamental, long, 1½"
4. Cap, ornamental, short, ½"
5. Plug, square head, 1½"
6. Locknut, malleable iron
7. Locknut, conduit, cadmium plated
8. Lock washer, internal tooth, cadmium plated
9. Lock ring, serrated
10. Washer, flat, aluminum
11. Washer, neoprene
12. Washer, cork
13. Cap, stud, mono (available in yellow, green, and black only)
14. Terminal block, 5-position (other sizes also available)

Pipe and Nipples

Details to Include When Ordering:

1. Length
2. Color
3. Type of ends
 - OE = Open End (not threaded)
 - TOE = Threaded On End
 - DP = Drop Pipe (3" threads)

Examples:

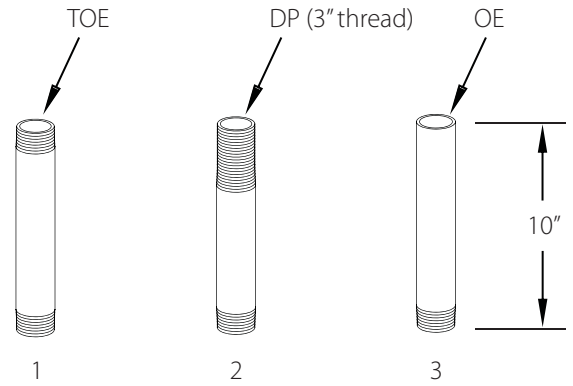

Designations for pipe above:

- Pipe No. 1 10", color, TOE, TOE
- Pipe No. 2 10", color, TOE, DP
- Pipe No. 3 10", color, TOE, OE

Framework Bolts and Hardware

Hot-Dipped Galvanized, Extended Thread Length

Bolts available in 1/2-13 UNC and 5/8-11 UNC (City of LA):

6", 8", 9", 10", 12", 14", 16", and 18" lengths

Additional available lengths in 1/2" only:

7", 20", 22", and 24"

Bolt Assembly:

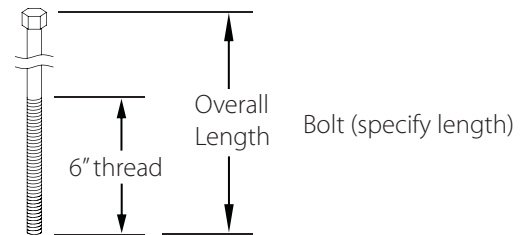

- Flat Washers (2)
- Curved Washer
- Lock Washer
- Hex Nut

A complete bolt assembly consists of 2 flat washers, a curved washer, a lock washer, a hex nut, and a bolt of a specified length

To learn more about McCain's Integrated Traffic Solutions, please contact info@mccain-inc.com or call (760) 727-8100

